

HYDRODUCT[®] 220

Pre-fabricated geocomposite drain consisting of a studded polystyrene core covered with a nonwoven, needle punched polypropylene filter fabric and a smooth polymeric sheet

Product Description

HYDRODUCT[®]220 is a strong, preformed geocomposite drainage sheet system, comprising a hollow studded polystyrene core. This is covered on one side with a non-woven, needle punched polypropylene filter fabric and on the other side with a smooth polymeric sheet.

Applications

This drainage composite has been specially developed to provide a simple and highly practical collector and deflector of unwanted ground water and can be used with BITUTHENE[®] waterproof membranes. When installed it will minimise the build-up of percolated surface water against the structure or the waterproof membrane to increase the overall security and performance of the building structure. The construction of the studded sheet also creates an air void to isolate the structure from the effects of the surrounding ground.

An important feature of this system is that it can be used behind trench sheeting and other permanent shoring works to provide a sandwiched water collector/deflector layer to control infiltrated water.

Hydroduct 220 can also be used against existing structures or permanent works to allow PREPRUFE[®] membranes to be applied to the smooth polymeric sheet side of the drainage core in reverse tanking applications. Hydroduct 220 has been designed to withstand the ground pressures, compaction forces and wet concrete to provide a high water flow capacity of 3 litre/second/metre width. The drainage sheet must be connected into the site drainage system to minimise hydrostatic build-up and collect infiltrated water using perforated pipes wrapped and linked with the geotextile filter fabric to prevent clogging.

Product Advantages

- **Enhances waterproofing** - relieves water pressure from the structure and waterproofing membrane and eliminates hydrostatic pressure build-up.
- **Efficient water collector/deflector** - can be used behind trench sheeting and other permanent shoring works as a sandwich drainage layer between the reinforced concrete structure.
- **Smooth polymeric backing sheet** - protects waterproofing membranes from damage caused by high lateral soil pressure in deep wall construction.
- **Simple, convenient drainage layer** - alleviates and controls ground water to prevent its entry into substructures and basements.
- **Geotextile fabric filter** - allows ground water to pass into the drain core while restricting the movement of soil particles.
- **High flow capacity** - drains 3 litre/sec/metre width.

- **Rot proof** – unaffected by permanent immersion in water, bacteria, dilute acids and alkalis.
- **Economical** – eliminates imported aggregate drainage layers.
- **Studded core** – allows water to flow to designated drainage collection points

Installation

Hydroduct 220 must be securely located in position against existing or new construction by fastening with masonry nails, shot fired or pneumatic fixings to support the weight of the sheet and Bituthene membrane. The centres of the fixings will be dependent on the height of the wall, substrate material and profile. The geotextile filter fabric is always laid towards the water face to allow water entry with the smooth polymeric sheet against or ready to receive the Bituthene membrane. The sheets can be joined horizontally and vertically by overlapping the geotextile fabric and butt jointing the studded sheet.

Butt and Cut Jointing

Simple vertical laps and butt joints can be made by separating the geotextile fabric and making a weathered overlap.

Corners

Hydroduct 220 can be bent on site to form internal corners. External corners are formed by cutting the dimpled sheets at corners and providing an additional 100mm wide strip of the filter fabric to wrap around corner to prevent infiltration of soil or debris at the overlap joint.

Installation with drainage pipes

Peel back geotextile fabric from studded core. Place drain pipe against core, wrap with fabric and tuck behind core. Place a small amount of soil on fabric to hold in place prior to backfilling.

Sealing edges

All exposed edges of Hydroduct Sheet 220 should have extra fabric tucked behind core to seal leading edge to prevent soil from entering the core.

Use with Bituthene membranes

Bituthene self-adhesive membranes can be bonded to the smooth polymeric sheet without priming provided the surface is dry and clean. If joints in Hydroduct 220 are slightly out of alignment owing to irregularities of the substrate they should be overbanded with a 100mm wide strip of Bituthene before applying the overall membrane

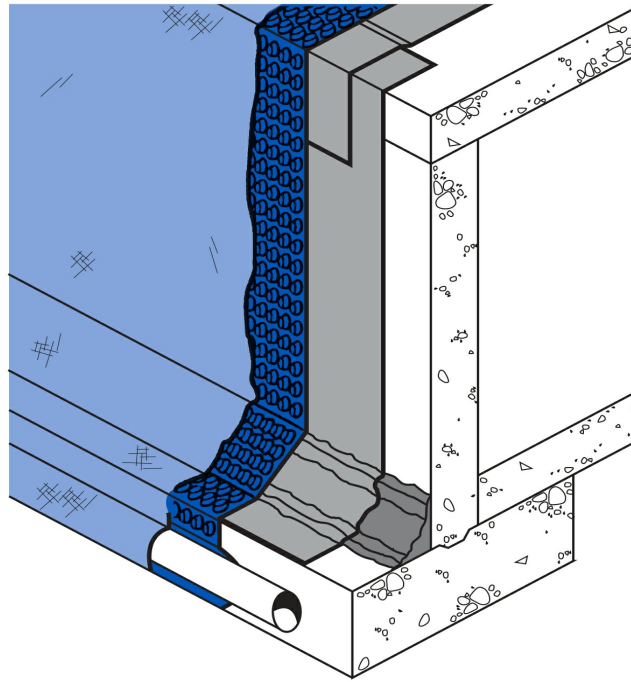

Physical Properties

Drainage Core

PROPERTY	TEST METHOD	TYPICAL VALUE
Polymer	N/A	High Impact Polystyrene
Thickness	ASTM C 366-B	9.5mm
Compressive Strength	ASTM D 1621	718kPa
Flow Rate	ASTM D 4716	3.0 litre/sec/metre width (gradient 0.1, 37.9 kPa)

Geotextile

PROPERTY	TEST METHOD	TYPICAL VALUE
Type	N/A	Non-woven
Polymer	N/A	Polypropylene
Weight	ASTM D 3776	136g / m ²
Tensile Strength	ASTM D 4632	450N x 600N
Trapezoidal Tear	ASTM D 4533	222N
Apparent Opening Size	ASTM D 4751	0.150 to 0.212mm
Permittivity	ASTM D 4491	6095 Litre / min / m ²

Supply

Hydroduct 220	1.22m x 15.25m long roll (18.6sq / m), weight 21.3kg
Storage	Keep under cover in original wrapping and cover immediately after installation.

Complementary Materials

Bitustik	150mm x 15.0m rolls
Bituthene Tape	50mm x 33m roll

Equipment by Others

Hammer drill with 6mm diameter masonry drill. Hilti DX 36M cartridge gun and cartridge 6.8/11M calibre, Aerosmith pneumatic nailer, refer to manufacturer for type of fixing. Stanley knife for trimming.

Specification

Hydroduct 220 drainage system shall be placed, fixed and terminated at the correct position to suit the ground levels and installed in accordance with the manufacturer's instructions and supplied by GCP Applied Technologies. For further information contact your local GCP representative.

Health and Safety

Refer to relevant Material Health and Safety data sheets.

Technical Services

For assistance with working drawings for projects and additional technical advice, please contact GCP Applied Technologies.

gcpat.id | For technical information: asia.enq@gcpat.com

Australia 1800 855 525 New Zealand +64 9 448 1146 China Mainland +86 21 3158 2888 Hong Kong +852 2675 7898 India +91 124 488 5900 Indonesia +62 21 893 4260 Japan +81 3 5226 0231 Korea +82 32 820 0800 Malaysia +60 3 9074 6133 Philippines +63 49 549 7373 Singapore +65 6265 3033 Thailand +66 2 709 4470 Vietnam +84 8 3710 6168

We hope the information here will be helpful. It is based on data and knowledge considered to be true and accurate, and is offered for consideration, investigation and verification by the user, but we do not warrant the results to be obtained. Please read all statements, recommendations, and suggestions in conjunction with our conditions of sale, which apply to all goods supplied by us. No statement, recommendation, or suggestion is intended for any use that would infringe any patent, copyright, or other third party right.

Hydroduct, Preprufe and Bituthene are trademarks, which may be registered in the United States and/or other countries, of GCP Applied Technologies, Inc. This trademark list has been compiled using available published information as of the publication date and may not accurately reflect current trademark ownership or status.

© Copyright 2017 GCP Applied Technologies, Inc. All rights reserved.

GCP Applied Technologies Inc., 2325 Lakeview Parkway, Alpharetta, GA 30009, USA

PT GCP Applied Technologies Indonesia, Cikarang Industrial Estate Kav C-32, Cikarang, Bekasi 17530

This document is only current as of the last updated date stated below and is valid only for use in Indonesia. It is important that you always refer to the currently available information at the URL below to provide the most current product information at the time of use. Additional literature such as Contractor Manuals, Technical Bulletins, Detail Drawings and detailing recommendations and other relevant documents are also available on www.gcpat.id. Information found on other websites must not be relied upon, as they may not be up-to-date or applicable to the conditions in your location and we do not accept any responsibility for their content. If there are any conflicts or if you need more information, please contact GCP Customer Service.

Last Updated: 2022-11-24

gcpat.id/solutions/products/hydroduct-drainage-composite/hydroduct-220